

# CHF 411.3 GRILL

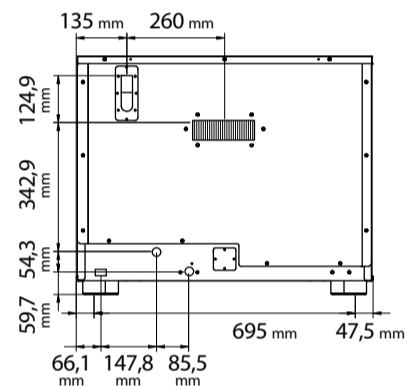

## ELECTRIC CONVECTION OVEN WITH GRILL AND HUMIDIFICATION

The electric grilling is a simple and healthy cooking method, which allows you to cook without fat all those foods that typically are prepared grilled. The GRILL functions of this oven 1/1 GN shortens the cooking time of the foods enhancing the browning and the fragrance of the same.

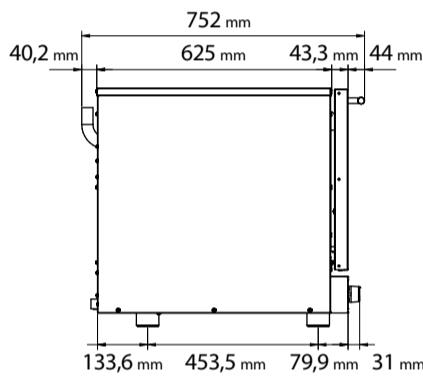
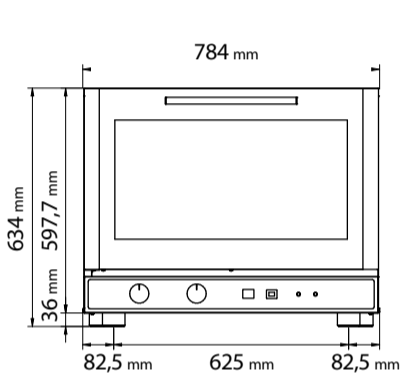

### DIMENSIONAL FEATURES

Oven dimensions (WxDxH mm)	784	752	634
Oven weight (kg)	52		
Distance between rack rails (mm)	73		

### ELECTRICAL FEATURES

Power supply (kW)	5,2
Frequency (Hz)	50/60
Voltage (Volt)	AC 380/400 2N
N° of motors	2 Unidirectional
Boiler	/
Protection against water	IPX3

### EQUIPMENT

Cardboard box dimensions with pallet (WxDxH mm)	805	830	800
Lateral supports	1 right + 1 left		
Cable	Two-phase [4G 2,5] – L=1600 mm		

### FUNCTIONAL FEATURES

Power	Electricity
Capacity	N° 4 trays/grids 1/1 GN
Type of cooking	Ventilated
Humidification	Indirect with button
Cooking chamber	AISI 430 Stainless steel
Temperature	50 ÷ 300°C
Temperature control	Thermostat
Control panel	Electromechanic – Lower side
N° of programs	/
Programmable cooking steps	/
Pre-heating temperature	/
Pre-heating function	/
Door	Tilt door Ventilated Inspectionable glass

### PLUS

Stainless steel cooking chamber
Door with inspectionable glass
Quick fastening of lateral supports
Embedded gasket
Stackable
Forced cooling system of inner parts
IPX 3
New design of cooking chamber
CB certification
New design of handle