

CHF 311 UD

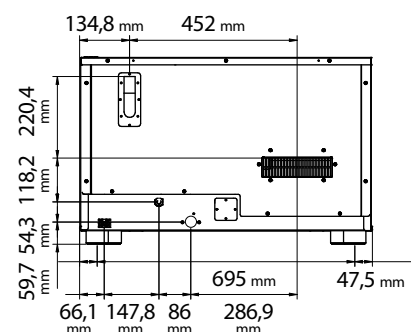

ELECTRIC COMBI OVEN

Speedy cooking and excellent results. Designed for small food outlets that need a sturdy, compact appliance but still want to be able to produce top-quality food. With its direct steam option, it offers unbeatable flexibility, catering to all cooking needs: you can heat sandwiches and frozen ready meals with great tasting and fragrant results every time.

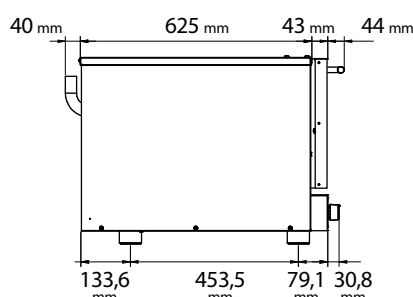
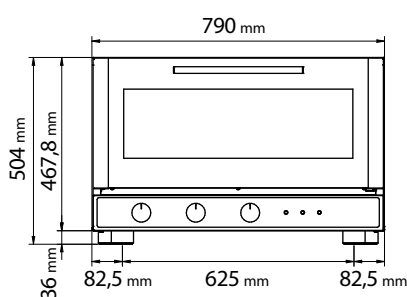

DIMENSIONAL FEATURES

Oven dimensions (WxDxH mm)	790	752	504
Oven weight (kg)	45		
Distance between rack rails (mm)	70		

ELECTRICAL FEATURES

Power supply (kW)	3,7
Frequency (Hz)	50 (60 on demand)
Voltage (Volt)	AC 220/230
N° of motors	1 Bidirectional
Boiler	/
Protection against water	IPX3

EQUIPMENT

Cardboard box dimensions with pallet (WxDxH mm)	805	830	670
Lateral supports	1 right + 1 left		
Cable	Single-phase [3G 1,5] - l=1350 mm		

FUNCTIONAL FEATURES

Power	Electricity
Capacity	N° 3 trays/grids 1/1 GN
Type of cooking	Ventilated
Steam	Direct steam controlled by knob (5 levels)
Cooking chamber	AISI 304 Stainless steel
Temperature	50 ÷ 300°C
Temperature control	Thermostat
Control panel	Electromechanic - Lower side
N° of programs	/
Programmable cooking steps	/
Pre-heating temperature	/
Pre-heating function	/
Door	Tilt door Ventilated Inspectionable glass

PLUS

Stainless steel cooking chamber
Door with inspectionable glass
Embedded gasket
Stackable
Forced cooling system of inner parts
IPX 3
New design of cooking chamber
CB certification
New design of handle