

# CHF 1011 TOP COMPACT



## Electric COMPACT combi oven with touch screen 10 trays 1/1 GN

Innovation in the MILLENNIAL line is never an end in itself. The new design simplifies the use of the oven in everyday life. The constructive quality makes it last in time.

The renewed convection cooking system helps cook all 10 trays evenly. Innovation has only one purpose in the MILLENNIAL line: allows you to fully express yourself.

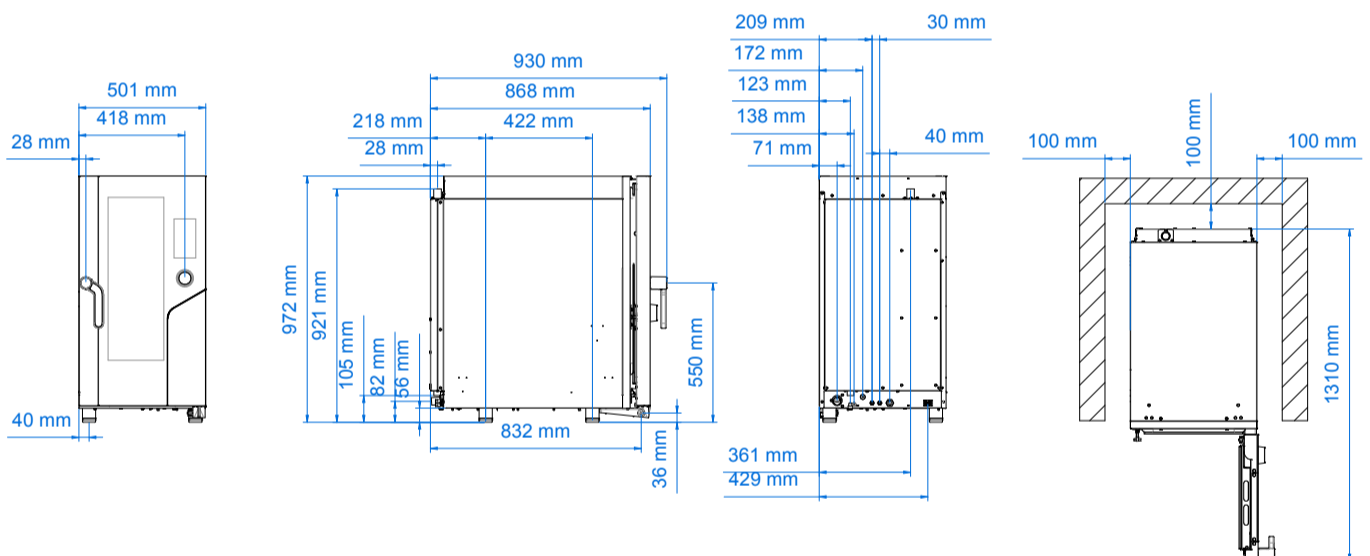

### Dimensional features

Dimensions (WxDxH mm)	500 x 930 x 970
Weight (kg)	100
Distance between rack rails (mm)	68

### Electrical features

Power supply (kW)	15,4
Frequency (Hz)	50/60
Voltage (V)	AC 380/400 3N
N° motors	2 bidirectional
Boiler (kW)	/
Protection against water	IPX5

### Functional features

Power	Electricity
Capacity	N° 10 trays/grids 1/1 GN
Type of cooking	Semistatic + ventilated
Steam	Direct steam controlled by touch screen (10 levels)
Cooking chamber	AISI 304 stainless steel
Temperature	30 - 270 °C
Temperature control	Digital probe thermometer
Control panel	Touch screen
N° programs	500
Programmable cooking steps	10
Pre-heating temperature	180 °C
Pre-heating function	Programmable
Door	Right side opening Ventilated Inspectionable glass
Modularity	Yes
Feet	Adjustable

### Equipment

Cardboard box dimensions with pallet (WxDxH mm)	570 x 980 x 1140 mm
Lateral supports	1 right + 1 left
Cable	Three-phase+neutral [5G 6]-L=1600 mm
USB port	
Multipoint core probe cod. MKSCMU	
Plug for "vacuum cooking" probe cod. MKSCSV	
Automatic washing system integrated	
Condensate collection bowl, with drain on door	
Hinge with door locking for openings adjusted at 60°, 90°, 120°, 180°	

### Plus

Patented fan guard system <b>Airflowlogic™</b>	
Patented system for direct steam <b>Humilogic™</b>	
Patented system for cooking chamber drying <b>Drylogic™</b>	
Available on request at the order	Voltage (V) : AC 220/230 3 Left side opening door
Humidity management software	
Wi-Fi communication system	
Knob for quick selection of the touch screen	
Programmable oven start	
N° 40 recipes stored	
Control panel in 40 languages:	Arabic, Armenian, Azerbaijani, Bahasa (Indonesia), Bahasa (Malaysia), Bosnian, Bulgarian, Czech, Chinese, South Korean, Croatian, Danish, Philippine, Finnish, French, Georgian, Japanese, Greek, English, Icelandic, Italian, Kazakh, Lithuanian, Norwegian, Dutch, Persian (Iran), Polish, Portuguese, Romanian, Russian, Serbian, Slovenian, Spanish, Swedish, German, Thai, Turkish, Ukrainian, Hungarian, Vietnamese
HACCP system	
Adjustable door hinges	