

CHAP. 7 - MAINTENANCE

ATTENTION! Before carrying out any cleaning operation, disconnect the power supply from the mains to completely isolate the Displayer from the rest of the plant.

7.1 - POWER SUPPLY CABLE MOD. BRIOCHE/HOT

Periodically check the wear of the power supply cable and eventually call the "After-Sales Centre" to replace it.

7.2 - FEET

With time, the feet might deteriorate and lose their elasticity features, decreasing the Displayer stability.

Therefore proceed to their replacement.

CHAP. 8 - DISMANTLING

8.1 - PLACING OUT OF ORDER

If, for any reason it should be decided to place the Displayer out of order, ensure it cannot be used by anyone: **disconnect the electrical connections.**



8.2 - RAEE Waste of Electrical and Electronic Appliances

According to art.13 of Legislative Decree 25 July 2005, n.151 "Implementation of Directives 2002/95/EC, 2002/96/EC and 2003/108/EC, concerning the restriction on the use of certain hazardous substances in electrical and electronic equipment, as well as the disposal of waste".

The symbol of the crossed out wheeled bin on the appliance or on its packaging indicates that, at the end of its life-span, the product must be collected separately from other waste.

Once reached the end of its life-span, the differential collection of this appliance is arranged and managed by the manufacturer. The user wanting to dispose of this appliance will therefore have to contact the manufacturer and follow the system adopted by him to allow the separate collection of the appliance that has reached the end of its life-span.

The adequate differential collection for the subsequent start of the appliance dismantled for recycling, treatment and compatible environmental disposal, contributes to avoid possible negative effects on the environment and on health, and favours the re-use and/or recycle of the materials composing the Displayer.

The unlawful disposal of the product on behalf of the owner, involves the application of administrative sanctions provided by the normative in force.

**AFTER-SALES CENTRE
AUTHORISED DEALER**



Displayer 30418612LF

USE AND MAINTENANCE INSTRUCTIONS BOOK

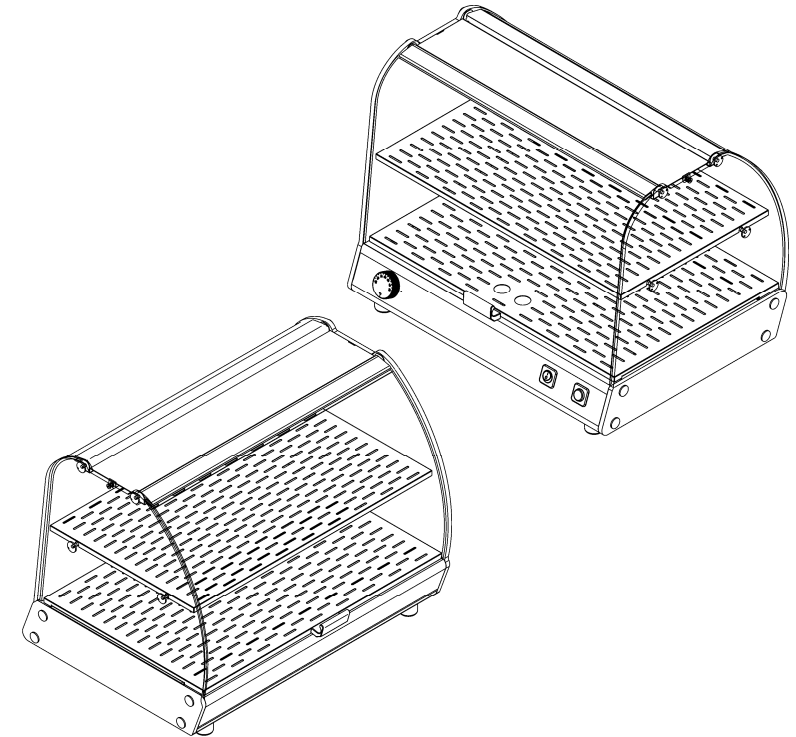

Ed. 11/2011

BD

Brioche / Hot

PREMISE

- This manual has been edited to supply the Client with all Displayer information and Standards applied to it, as well as the use and maintenance instructions for a better use of the mean, maintaining its efficiency intact in time.
- This manual must be handed to the persons in charge of using and maintaining the Displayer.

INDEX

CHAP. 1 - INFORMATION ON THE DISPLAYER	page 3
1.1 - GENERAL PRECAUTIONS	
1.2 - SAFETY DEVICES INSTALLED ON MODELS BRIOCHE AND HOT	
1.3 - DESCRIPTION OF THE DISPLAYER	
1.3.1 - general description	
1.3.2 - constructive features	
1.3.3 - composition of the Displayer	
CHAP. 2 - TECHNICAL DATA	page 5
2.1 - SIZE, WEIGHT, FEATURES, ...	
CHAP. 3 - RECEIVING THE DISPLAYER	page 5
3.1 - SHIPPING THE DISPLAYER	
3.2 - CHECKING THE PACKAGING UPON RECEIPT	
3.3 - DISPOSING OF THE PACKAGING	
CHAP. 4 - INSTALLATION	page 6
4.1 - PLACING THE DISPLAYER	
4.2 - ELECTRICAL CONNECTION	
4.3 - ELECTRICAL LAYOUT MOD. BRIOCHE/HOT	
CHAP. 5 - USE OF DISPLAYER	page 7
5.1 - CONTROLS	
5.2 - COMMISSIONING MOD. BRIOCHE/HOT	
CHAP. 6 - CLEANING THE DISPLAYER	page 7
6.1 - GENERALITY	
CHAP. 7 - MAINTENANCE	page 8
7.1 - POWER SUPPLY CABLE MOD. BRIOCHE/HOT	
7.2 - FEET	
CHAP. 8 - DISMANTLING	page 8
8.1 - PLACING OUT OF ORDER	
8.2 - RAEE Waste of Electrical and Electronic Appliances	

4.3 - ELECTRICAL LAYOUT MOD. BRIOCHE/HOT

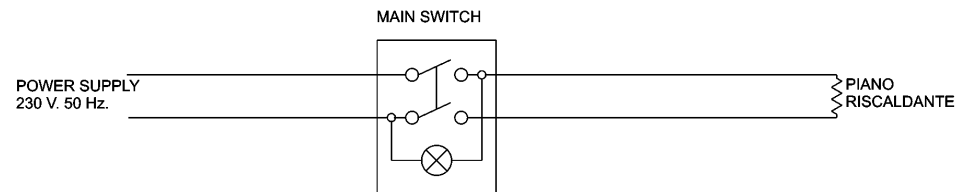
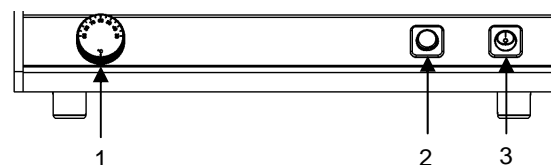

Fig.n.5 - Single phase electrical layout 230V/50Hz

CHAP. 5 - USE OF DISPLAYER

5.1 - CONTROLS MOD. BRIOCHE/HOT

The controls are arranged as follows:



1. Thermostat, when at position "0" the resistances are switched off.
2. Luminous indicator, signals the presence of current.
3. Interruttore 0/1.

Fig.n.6 - Briche/Hot Controls position

5.2 - COMMISSIONING mod. Briche/Hot

The Displayer is delivered with the external surfaces protected by a non-scratch nylon film, therefore accurately remove this film and any glue residue before operating it. For such operations, remember not to use pointed tools, abrasive and/or flammable substances.

At this point operate the appliance in the open, at maximum power for 15-20 minutes. This is because the thermal insulators used in the construction of the same appliance and grease residue due from the mechanical manufacture of the single pieces, produce smokiness when heated up.

CHAP. 6 - USING THE DISPLAYER

ATTENTION! Before carrying out any cleaning operation, disconnect the power supply from the mains to completely isolate the Displayer from the rest of the plant.

6.1 - GENERALITY

- The Displayer must be cleaned with normal neutral cleansing agents at room temperature, with the aid of a previously soaked cloth. All parts of the Displayer which come into contact with the product must be scrupulously cleaned.
- High pressure cleaning Displayers or strong pressure water jets must not be used.
- Tools, scrubbers, and anything else which might damage the Displayer on the surface must not be used.

3.2 - CHECKING THE PACKAGING UPON RECEIPT

Upon receiving the package containing the Displayer, accurately check the packaging to check it did not sustain any serious damages during transport.

If, when examining the outside, the package shows signs of mistreatments, impacts or falls, show the damage to the carrier and, within three days from the delivery date indicated on the documents, draft a precise report on the damages sustained by the Displayer.

3.3 - DISPOSING OF THE PACKAGING

The components of the packaging (cardboard, any pallet, plastic and polyurethane foam strap) are products assimilable with municipal solid waste; for this reason, they can be disposed of without difficulty.

In case the Displayer is installed in countries where particular Standards exist, dispose of the packaging in compliance with that prescribed in the Standards in force.

CHAP. 4 - INSTALLATION

4.1 - PLACING THE DISPLAYER

Once mounted the Displayer and fixed its every part correctly, move on to placing it.

The surface on which the appliance is to be located must allow for the surface dimensions indicated in the Technical data table, and therefore be sufficiently wide, correctly levelled, dry, smooth, robust, stable and be 80cm from the ground.

Also, the appliance must be installed in an airy room.

Should the Displayer be placed near walls, keep a distance of at least 5cm between the Displayer and the walls.

4.2 - ELECTRICAL CONNECTION MOD. BRIOCHE/HOT

The appliance is equipped with a power supply cable with 3x1.5 mm.² section, 1.5m long and a SHUKO plug.

Connect the Displayer 230 Volt 50 Hz, inserting a 15A, $\Delta I = 0.03A$ magneto-thermal—differential switch.

Ensure the earthing plant is perfectly functioning.

Also check that the data reported on the technical—serial number plaque (see Fig.n.4) corresponds to the data reported on the delivery and accompanying documents, and that the switch and plug are easily accessible during use of appliance.

Mod.	_____
Matr.	_____ Watt.
_____ H.p.	_____ A. _____ Hz.
○ _____	~ Volts. _____ Kg. ○
Anno	_____

Fig.n.4 - Technical - serial number plaque

CHAP. 1 - INFORMATION ON THE DISPLAYER

1.1 - GENERAL PRECAUTIONS

- The Displayer must only be used by trained personnel who must be perfectly aware of the safety Standards contained in this manual.
- In case of personnel turnover, provide training in time.
- **Avoid going near the hot parts with the hands.**
- **Disconnect the Displayer from the mains before cleaning and maintaining.**
- When intervening for Displayer maintenance or cleaning, carefully evaluate the residue risks.
- During maintenance or cleaning, keep concentrated on the operations in progress.
- Periodically check the state of the power supply cable; a worn cable or not intact, represents a serious electrical danger.
- Should the Displayer give reason to presume or show a malfunctioning, do not use it and call the "After-Sales Centre".
- Only use the Displayer for food products.
- Do not directly repair but always refer to authorised repairers.
- The manufacturer is lifted of every responsibility in the following cases:
 - ⇒ the Displayer is tampered with by unauthorised personnel;
 - ⇒ components are replaced with other non originals;
 - ⇒ the instructions in this annual are not attentively followed;
 - ⇒ the Displayer surfaces are treated with unsuitable products.

1.2 - SAFETY DEVICES INSTALLED ON MODELS Briocche/Hot

The safety devices against electrical and mechanical risks have been introduced in compliance with **EEC 2006/42** Standards.

Therefore, the Displayer is equipped with safety devices for the electrical and mechanical protections, both during functioning and during cleaning and maintenance.

However, "**Residue risks**" which cannot be completely removed, do exist. They are recalled in this manual under form of "**ATTENTION**", and they refer to the danger of burns deriving from the loading and unloading operations, and during Displayer cleaning.

1.3 - DESCRIPTION OF THE DISPLAYER

1.3.1 - general description

The Displayer has been designed and realised by our company, with the precise aim of guaranteeing:

- maximum hygiene due to the careful selection of the materials which come into contact with the food product to be heated;
- minimum heat dispersion produced by the resistances;
- robustness and stability of all its components;
- ease of handling.

1.3.2 - constructive features

The Displayer is made of anodised aluminium, stainless steel and Plexiglas.

Materials which guarantee healthfulness and unassailability from acids and salts, as well as an excellent resistance to oxidation.

1.3.3 - composition of the Displayer

Fig.n.1 - Displayer general view

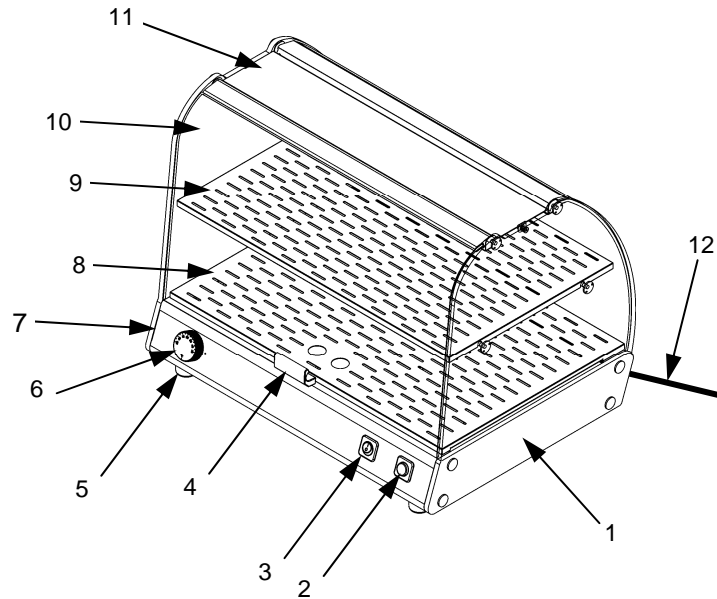

Key:

- 1 Side covering (thrust block)
- 2 O/I Switch on mod. Brioche/Hot
- 3 Indicator light on mod. Brioche/Hot
- 4 Handle
- 5 Foot
- 6 Thermostat on mod. Brioche/Hot
- 7 Base
- 8 Product support surface
- 9 2° Product support surface on mod. Brioche/Hot
- 10 Door
- 11 Lid
- 12 Power supply cable on mod. Brioche/Hot

CHAP. 2 - TECHNICAL DATA

2.1 - SIZE, WEIGHT, FEATURES, ...

Fig. n.2 - Displayer dimensions and maximum sizes

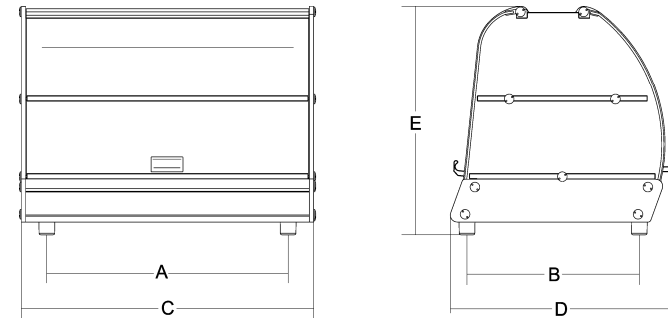

	Power	Thermostat	Lower surface	Upper surface	AxB	CxDxE	Net weight
	watt	°C	mm	mm	mm	mm	kg
BD	-	-	530x350	530x320	450x325	550x405x425	13
BD Brioche	300	(*) max 40	530x350	530x320	450x325	550x405x425	15
BD Hot	450	(*) max 70	530x350	530x320	450x325	550x405x425	15

* **Temperature of product support lower surface.**
The internal temperature of the Displayer is not guaranteed.

ATTENTION! The electrical features for which the Displayer is provided, are indicated at the back of the same; before carrying out the electrical connection, read paragraph 4.2 "Electrical connection".

CHAP. 3 - RECEIVING THE DISPLAYER

3.1 - SHIPPING THE DISPLAYER

The Displayers leave our warehouses after having been accurately packed.

The packaging is made of:

- external robust cardboard box;
- the dismantled Displayer;
- this manual.

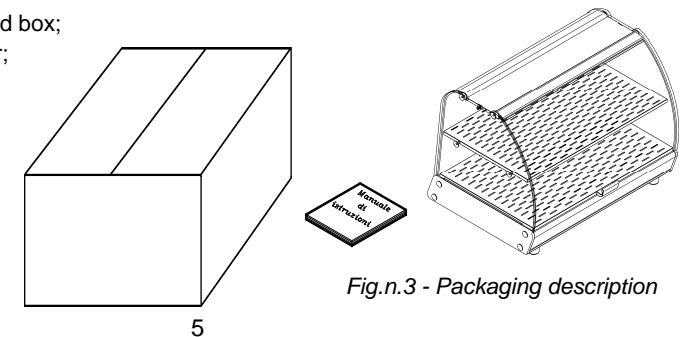

Fig.n.3 - Packaging description